

No ROHS hazardous material

Ordinal	Modify content description	Cartographer	Date of change
△			
△			

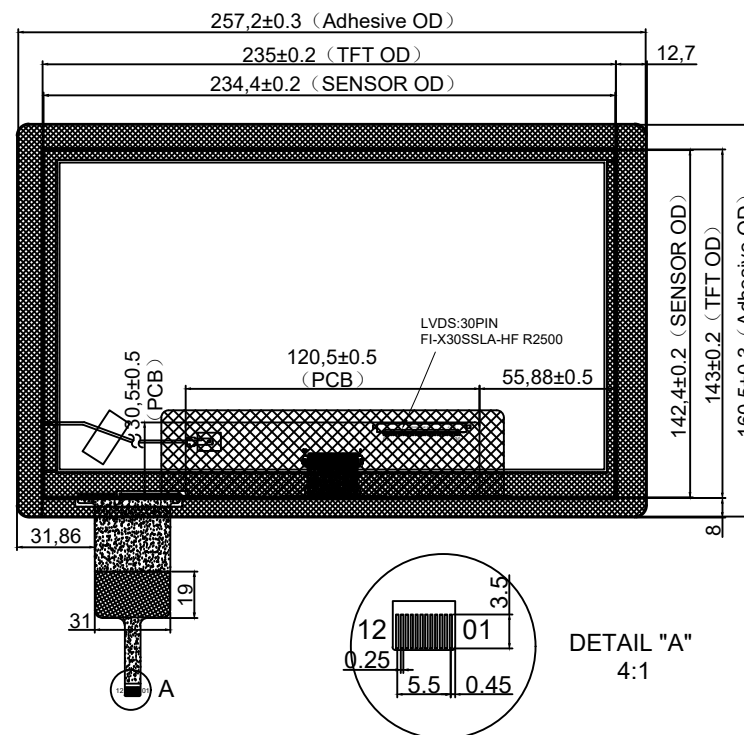
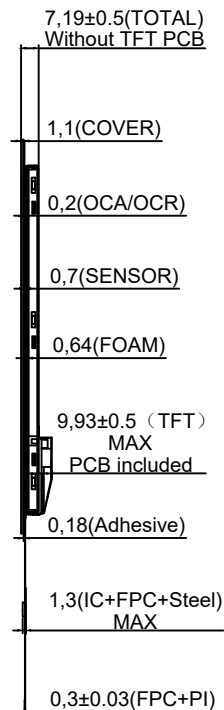
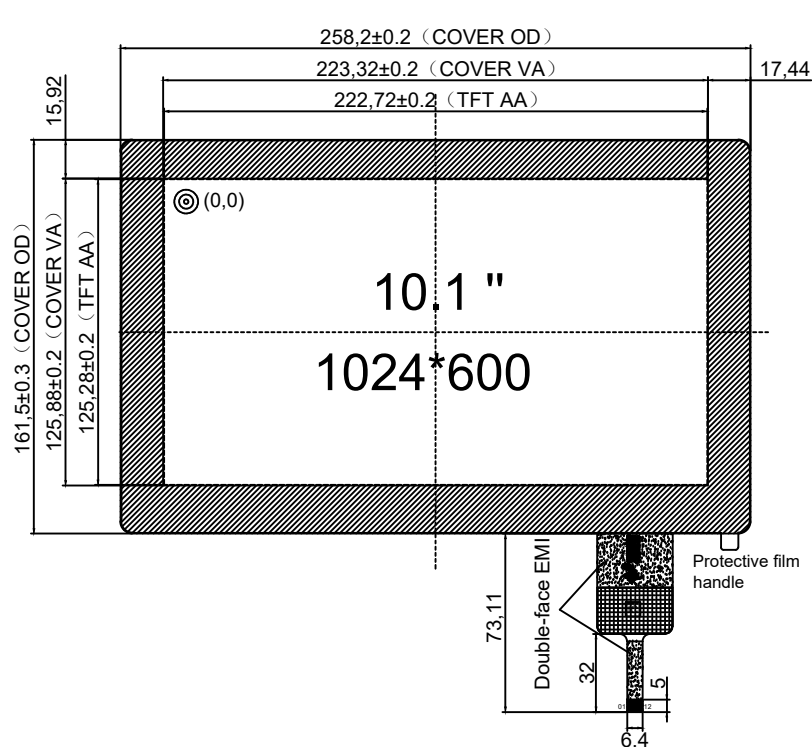

- Screen printing area: Print Black
- FOAM: 3M5925(VHB)=0.64MM

- Adhesive: 3M9495(300le)
- TFT: HX101NIL36-30L01

Front view

Side view

Back view

TP Technical parameters			
1.Interfaces	I2C	7.Humidity range	45~85%RH
2. Structure	G+G+TFT (AIR bonding)	8.Transmittance	≥85%
3.IC solutions	CYTMA568	9. Hardness	≥6H
4.Impact	30.0ΦD1A, SteelBall 1/32g/Height=35cm/11ms	10. Operate	-20℃~+70℃, ≤85%RH
5.Touch points	10 points	11. Storage	-30℃~+80℃, ≤85%RH
6.Power supply	3.3V	12.Unmarked dimension tolerance	as±0.2

TP PIN:			
1	GND	7	SDA3.3V
2	NC	8	SCL3.3V
3	NC	9	RST3.3V
4	NC	10	INT3.3V
5	SDWIO/NC	11	VDD3.3V
6	GND	12	VCC3.3V

		杭州宏巢科技有限公司 GraHowlet Technology CO., Ltd					
Model	HX1011833		view direction		Unit	MM	
Version	V1.0	Designer	LUO	Date	2021-11-01	Edition	A1
Customer	Approved		Date		Proportion	1:1	